

Spec.Description Model : SD01/SD03/SD15

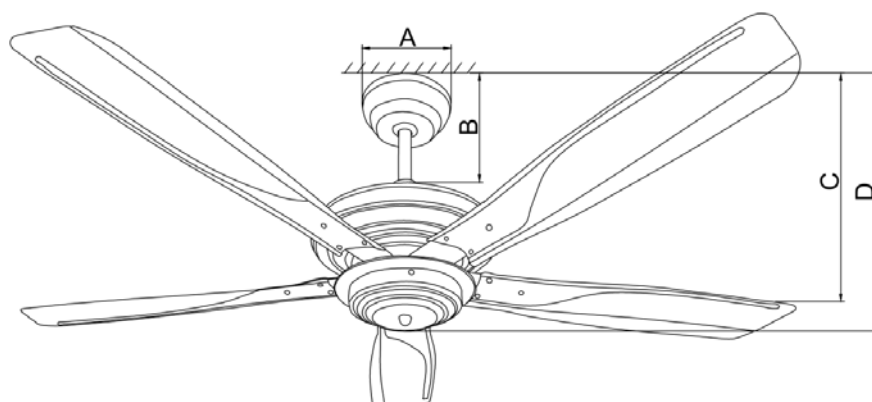

TISI Model: (安規代號)	WF556CP			Fridgecode 條碼	SD01# 8858786401533 SD03# 8858786401557 SD15# 8858786402516	
Code: (型號)	SD01/SD03/SD15			Color: (顏色)	SD01# = AB(古銅) SD03# = GM(珍珠黑) SD15# = S.S(砂石灰)	
Specification (規格)	56 inch/5 Blades /No L			Motor Size 馬達規格	AC/188*15	
Material (材料)	Steel (鐵葉)			Switch Category 開關類別	Infrared Remote Control <QF-R8-A (2.5+3 uF)>	
Speed 轉速	Current (A) 安培	Wattage (W) 瓦特	RPM 轉速	Air Flow (CFM) 風量	Efficiency (CFM/Wattage)	
1 速	0.36	76	220	5200	68	
2 速	0.32	43	160	3105	72	
3 速	0.25	21	100	2000	95	
4 速	-	-	-	-	-	
5 速	-	-	-	-	-	
Fan	A	吊盅直徑 Diameter of downrod			15	cm
	B	天花板到上罩高度 Height of Ceiling to upper cover			19	cm
	C	天花板到葉片高度 Height of Ceiling to blades			41.5	cm
	D	天花板到馬達底部高度 Height of ceiling to motor bottom			46.5	cm
	E	天花板到玻璃高度 Height of ceiling to glass			-	cm
Carton	L (長)	64.2				cm
	W (寬)	36.4				cm
	H (高)	23.7				cm
Package	N.W(淨重)	9.31 KG				KGS
	G.W(毛重)	10.31 KG				KGS