

Spec.Description Model : TW01,TW02

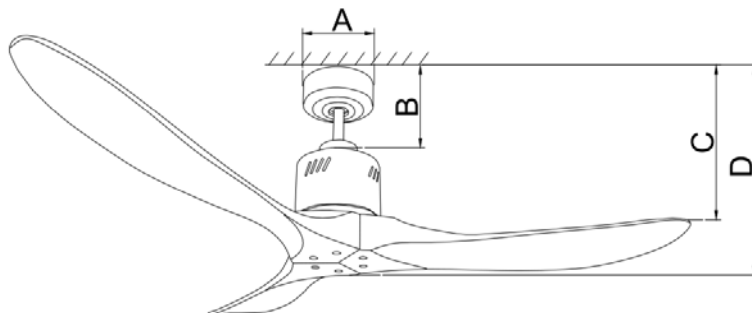

TISI Model: (安規代號)	WF556CP			Fridgecode 條碼	TW01 = 8858786402554 TW02 = 8858786402561	
Code: (型號)	TW01,TW02			Color: (顏色)	TW01 = 砂鏢 (BN) TW02 = ORB+金 (ORB+G)	
Specificatio n (規格)	56 inch/3 Blades/No L			Motor Size 馬達規格	AC/153*20	
Material (材料)	WOOD			Switch category 開關類別	Remote control set WFSP-YJF(2+3UF)双继电器	
				Energy Information At High Speed		
				Air Flow (CFM) 風量	Efficiency (CFM/Wattage)	
Speed 轉速	Current (A) 安培	Wattage (W) 瓦特	RPM 轉速			
1 速	0.31	66	195	6000	85.7	
2 速	0.23	35	135	-	-	
3 速	0.17	20	85	-	-	
4 速	-	-	-	-	-	
5 速	-	-	-	-	-	
Fan	A	吊盅直徑 Diameter of downrod			15	cm
	B	天花板到上罩高度 Height of Ceiling to upper cover			19	cm
	C	天花板到葉片高度 Height of Ceiling to blades			33	cm
	D	天花板到馬達底部高度 Height of ceiling to motor bottom			37	cm
	E	天花板到玻璃高度 Height of ceiling to glass			-	cm
Carton	L (長)	73				cm
	W (寬)	26				cm
	H (高)	42				cm
Package	N.W(淨重)	7.17				KGS
	G.W(毛重)	8.30				KGS

Spec.Description Model : TW01,TW02

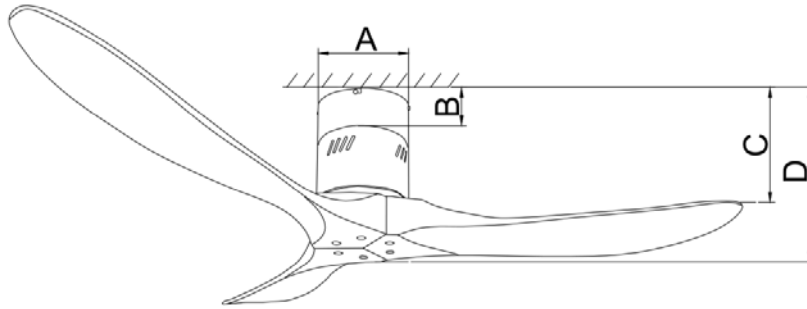

TISI Model: (安規代號)	WF556CP	Fridgecode 條碼	TW01 = 8858786402554 TW02 = 8858786402561			
Code: (型號)	TW01,TW02	Color: (顏色)	TW01 = 砂鏢 (BN) TW02 = ORB+金 (ORB+G)			
Specificatio n (規格)	56 inch/3 Blades/No L	Motor Size 馬達規格	AC/153*20			
Material (材料)	WOOD	Switch category 開關類別	Remote control set WFSP-YJF(2+3UF)双继电器			
Energy Information At High Speed						
Speed 轉速	Current (A) 安培	Wattage (W) 瓦特	RPM 轉速	Air Flow (CFM) 風量	Efficiency (CFM/Wattage)	
1 速	0.31	66	195	6000	85.7	
2 速	0.23	35	135	-	-	
3 速	0.17	20	85	-	-	
4 速	-	-	-	-	-	
5 速	-	-	-	-	-	
Fan	A	吊盅直徑 Diameter of downrod			17	cm
	B	天花板到上罩高度 Height of Ceiling to upper cover			7	cm
	C	天花板到葉片高度 Height of Ceiling to blades			21	cm
	D	天花板到馬達底部高度 Height of ceiling to motor bottom			25	cm
	E	天花板到玻璃高度 Height of ceiling to glass			-	cm
Carton	L (長)	73				cm
	W (寬)	26				cm
	H (高)	42				cm
Package	N.W(淨重)	7.17				KGS
	G.W(毛重)	8.17				KGS